

# Float trap with thermostatic air vent

Flanged DIN PN 16 Threaded end BSPP

The BV500 is a float & thermostatic style steam trap with an inline, straight-through body design, which eliminates the staggered piping usually associated with this type of steam trap. It utilizes a stainless steel float and a simple lever mechanism to open or close the valve in correlation to the amount of condensate present. The opening is proportional to the condensate rate and is unaffected by instantaneous pressure changes. The BV500 is used where fast response and continuous condensate discharge is required such as on heat exchangers, tanks, pans, ovens, and drying cylinders.

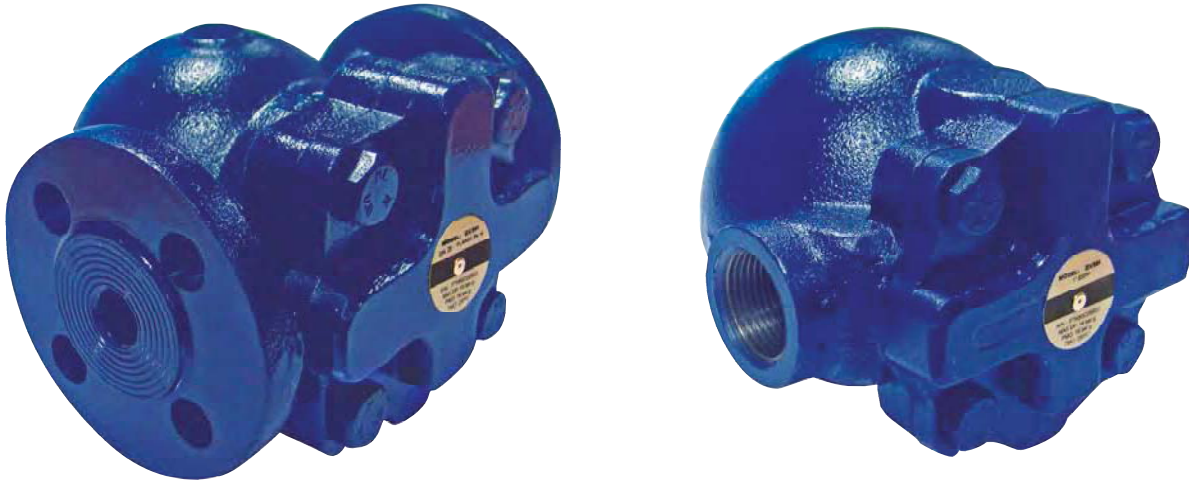

## Dimensions and weight flanges connection

DN	15	20	25	40	50
A	150	150	160	320	320
B	53	53	58	130	138
C	54	54	59	108	122
D	51	55	100	242	250
Weight (Kg)	3,2	3,2	4,7	17,6	22

Dimensions in mm.

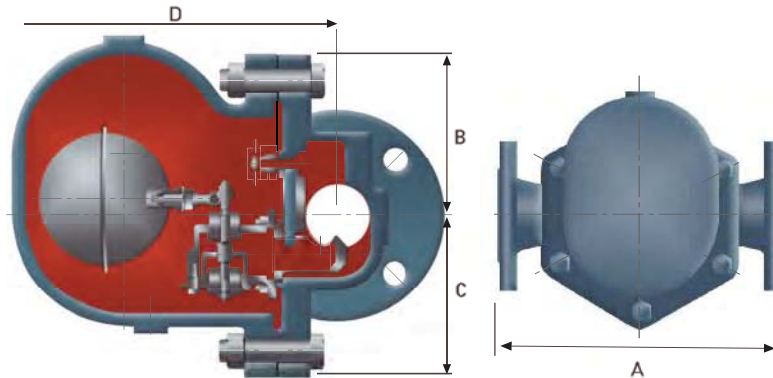

## Dimensions and weight thread connection

DN	1/2"	3/4"	1"	1-1/2"	2"
A	122	122	145	270	300
B	108	108	108	238	260
C	150	150	167	281	294
D	68	68	75	34	40
E	-	-	-	247	254
F	-	-	-	111	127
G	-	-	-	206	213
Weight (Kg)	3,2	3,2	4,7	17,6	22

Dimensions in mm

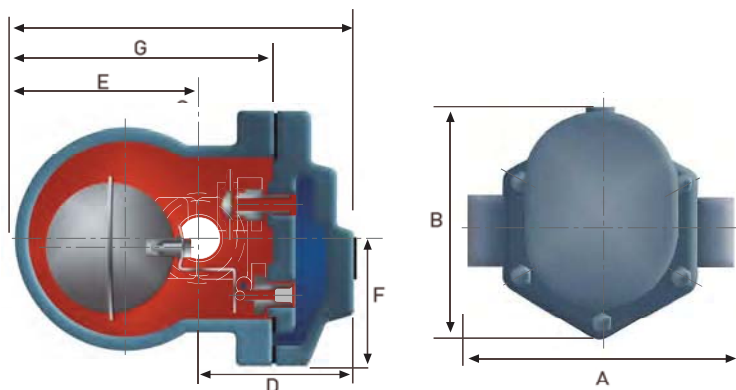

# BV500

Max. operating temperature: 250°C

Operating pressure: 16 bar g

## Installation

The BV500 steam trap must be fitted with the float arm in a horizontal plane so that the float will rise and fall vertically within the trap body. Nominal sizes DN 15, DN 20 and DN 25 can be installed both in horizontal and vertical pipes by turning the cover 90°.

## Specifications

Sizes: DN 15, DN 20, DN 25, DN 40 and DN 50  
 End connections: Flanged DIN PN 16 / Thread end BSPP  
 Maximum Allowable Pressure: 25 bar  
 Maximum Allowable Temperature: 300°C  
 Maximum Operating Pressure: 16 bar  
 Maximum Differential Pressure: 4,5 bar, 10 bar, 14 bar  
 Maximum Operating Temperature: 250°C

## Materials:

Body & Cover: Ductile iron GGG 40.3  
 Thermostatic Capsule: Stainless steel  
 Air Vent Seat / Float Seat: Stainless steel 304  
 Main Valve (Ball): Stainless steel 304  
 Float & Float Lever: Stainless steel 304

## Discharge capacities

Differential Pressure Barg	ΔP4,5 (A)				ΔP10 (B)				ΔP14 (C)			
	1/2"-3/4"	1"	1-1/2"	2"	1/2"-3/4"	1"	1-1/2"	2"	1/2"-3/4"	1"	1-1/2"	2"
0.1	115	365	1100	3500	55	187	660	1800	38	68	450	850
0.2	160	425	1450	4800	75	211	925	1600	52	90	625	1250
0.3	180	491	1800	6000	89	249	1150	3100	62	101	750	1450
0.4	190	523	2150	6950	100	280	1300	3500	70	133	850	1700
0.6	225	601	2650	8500	125	314	1625	4250	82	145	1050	2150
0.8	260	689	2950	9600	140	359	1825	4800	93	159	1200	2500
1	275	721	3250	12500	160	391	2125	5400	100	172	1300	2750
2	360	901	4500	15000	200	483	3000	7500	135	224	1800	3600
3	425	1003	5500	17500	240	552	3600	9200	170	272	2250	4500
4.5	500	1225	6700	22500	280	608	4400	11250	190	316	2750	5500
5					300	653	4600	11850	200	323	2900	5850
6					320	699	5100	13100	220	349	3200	6400
8					360	749	6000	15000	250	401	3600	7500
10					400	801	6700	16300	270	451	4000	8400
14									310	503	4700	9500

Notes: 1. Discharge capacities in Kg/h with outlet pressure 0 bar.

